

Depth Gage

SERIES 527, 571 — Hook End Type

FEATURES

- The end of the main scale is hook-shaped to allow depth and thickness measurements of a projected portion or lip in a hole, in addition to standard depth measurement.
- Fine-adjustment models are available.
- Optional wider extension bases are available.
- SPC output (Series 571).

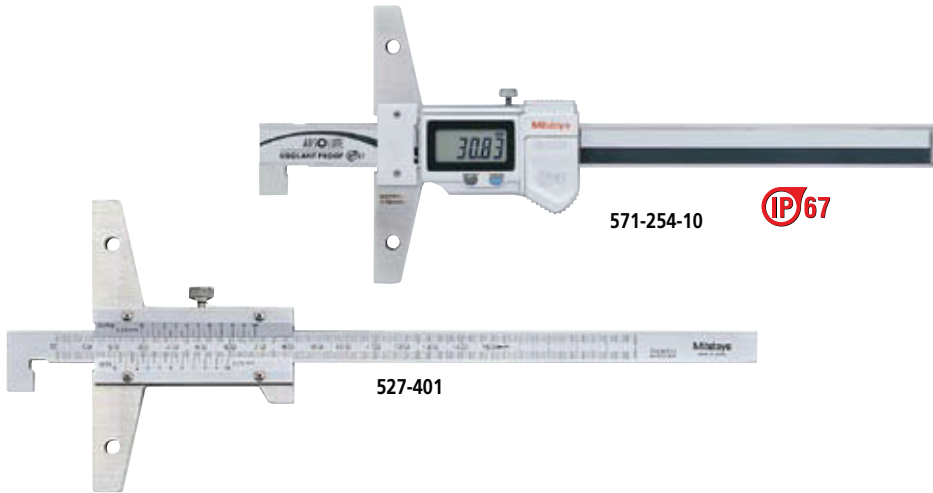

SPECIFICATIONS

Metric	Digital model			
Range: L1 (L2 and L3)	Order No.	Resolution	Accuracy	
10 - 160mm (0 - 150mm)	571-254-10	0.01mm	±0.03mm	
10 - 210mm (0 - 200mm)	571-255-10	0.01mm	±0.03mm	

Inch/Metric	Digital model			
Range: L1 (L2 and L3)	Order No.	Resolution	Accuracy	
.4" - 6.4" (0 - 6")	571-264-10	.0005" / 0.01mm	±0.03mm	
.4" - 8.4" (0 - 8")	571-265-10	.0005" / 0.01mm	±0.03mm	

Metric				
Range: L1 (L2 and L3)	Order No.	Vernier reading	Accuracy	
10 - 150mm (0 - 150mm)	527-401	0.05mm	±0.05mm	
10 - 200mm (0 - 200mm)	527-402	0.05mm	±0.05mm	
10 - 300mm (0 - 300mm)	527-403	0.05mm	±0.08mm	

Metric	with fine adjustment			
Range: L1 (L2 and L3)	Order No.	Vernier reading	Accuracy	
10 - 150mm (0 - 150mm)	527-411	0.02mm	±0.03mm	
10 - 200mm (0 - 200mm)	527-412	0.02mm	±0.03mm	
10 - 300mm (0 - 300mm)	527-413	0.02mm	±0.04mm	

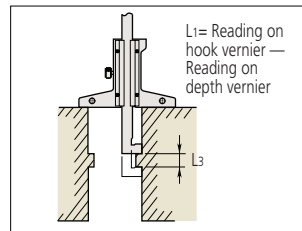
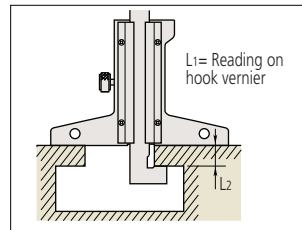
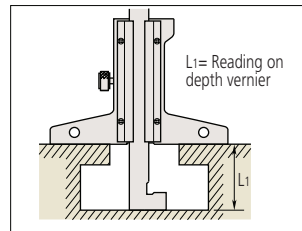

DIMENSIONS

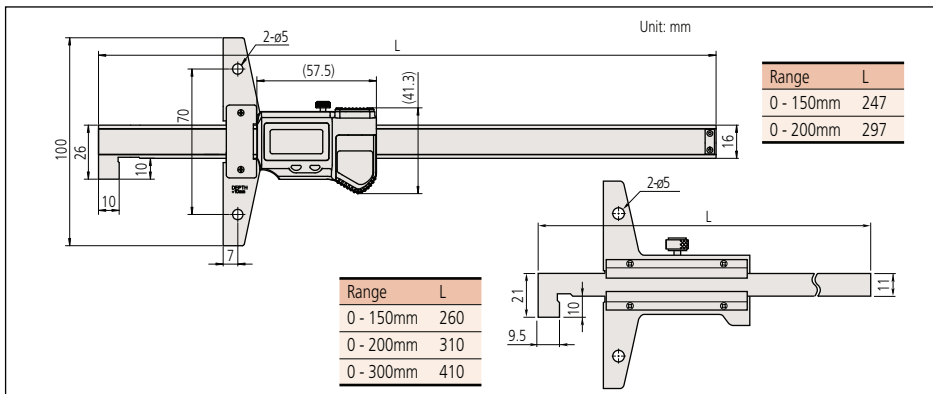

(Refer to the VIII for details.)



(Refer to page VIII for details.)

Technical Data

Accuracy: Refer to the list of specifications.
(excluding quantizing error for digital models)
Resolution*: 0.01mm or .0005"/0.01mm
Graduation**: 0.05mm or 0.02mm
Repeatability*: 0.01mm
Display*: LCD
Scale type*: ABSOLUTE electromagnetic linear encoder
Max. response speed*: Unlimited
Battery*: SR44 (1 pc.), **938882**
Battery life*: Approx. 3 years under normal use
Dust/Water protection level*: IP67
*Digital models **Analog models

Functions of Digital Model

Origin-set, Zero-setting, Automatic power on/off, Data output, inch/mm conversion (inch/mm models)
Alarm: Low voltage, Counting value composition error

Optional Accessories

05CZA624: SPC cable with data switch (1m)*
05CZA625: SPC cable with data switch (2m)*
02AZD790A: SPC cable for U-WAVE w/ data switch (160mm)*
_____: Extension base (see page D-55.)
*For digital models